



MODEL CC1 - Freezer capacity 75Lt
Drawers Freezer (-10° C -20° C) with remote compressor.
 The internal walls are in 304BA (polished) stainless steel, while the external front and door are in 316SB (brushed) stainless steel.

The refrigeration unit is available at 12 / 24Vdc, 110Vac 60Hz or at 220Vac 50Hz with forced air or water cooling.

Our refrigerators are made of high quality stainless steel and are also suitable for outdoor use, provided they are protected from the elements with appropriate covers.

Various options are also available.

STAR	TEMPERATURE	FROZEN FOOD STORAGE	FRESH FOOD STORAGE	MAXIMUM STORAGE
★	-6°	YES	NO	STORAGE 1 WEEK
★★	-12°	YES	NO	STORAGE 1 MONTH
★★★	-18°	YES	NO	STORAGE 1 YEAR
★★★★	-18°	YES	YES	STORAGE 1 YEAR

CODICE PRODOTTO / PRODUCT CODE	REVISIONE / REVISION:
mod. CC1	R04
	DATA / DATE:
	01/01/2023



Via Confin 64, 30020 Torre di Mosto (Venezia) Italia Tel: +39 0421.325214 - Fax: +39 0421.325343
 E-Mail: info@frigonautica.it - P.IVA: 03687150270
www.frigonautica.it

PROPRIETA' DI FRIGONAUTICA srl
 Senza autorizzazione scritta della stessa il presente disegno non potrà essere utilizzato per la costruzione dell'oggetto rappresentato, nè venire comunicato a terzi o riprodotto anche parzialmente. La società proprietaria tutela i propri diritti a rigor di legge.
 ALL PROPRIETARY RIGHT RESERVED BY FRIGONAUTICA srl
 This drawing shall not be reproduced also partially or in any way utilized for the manufacture of the component or unit herein illustrated and must not be released to other parties without written consent. Any infringement will be legally pursued.

SPECIFICATIONS

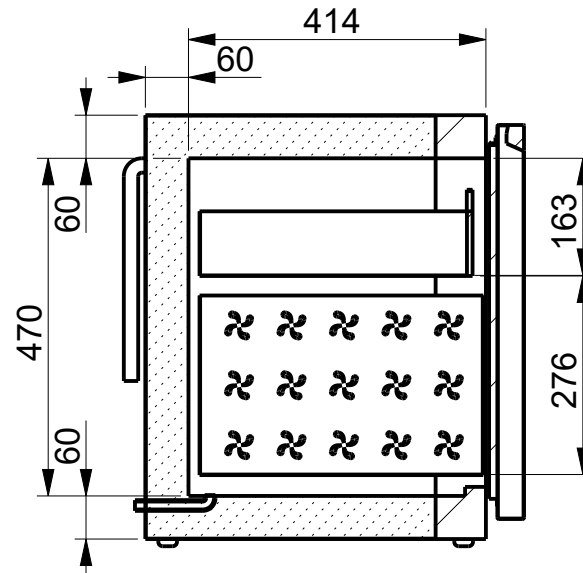
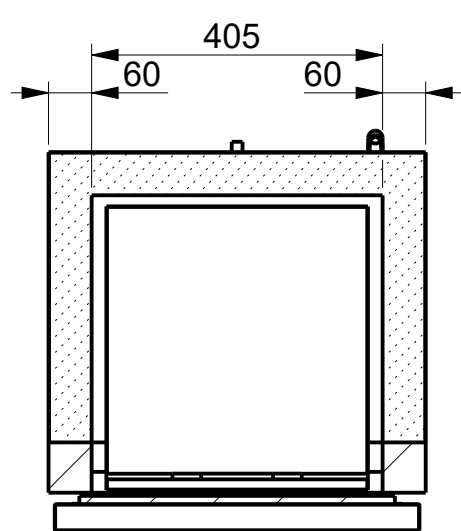
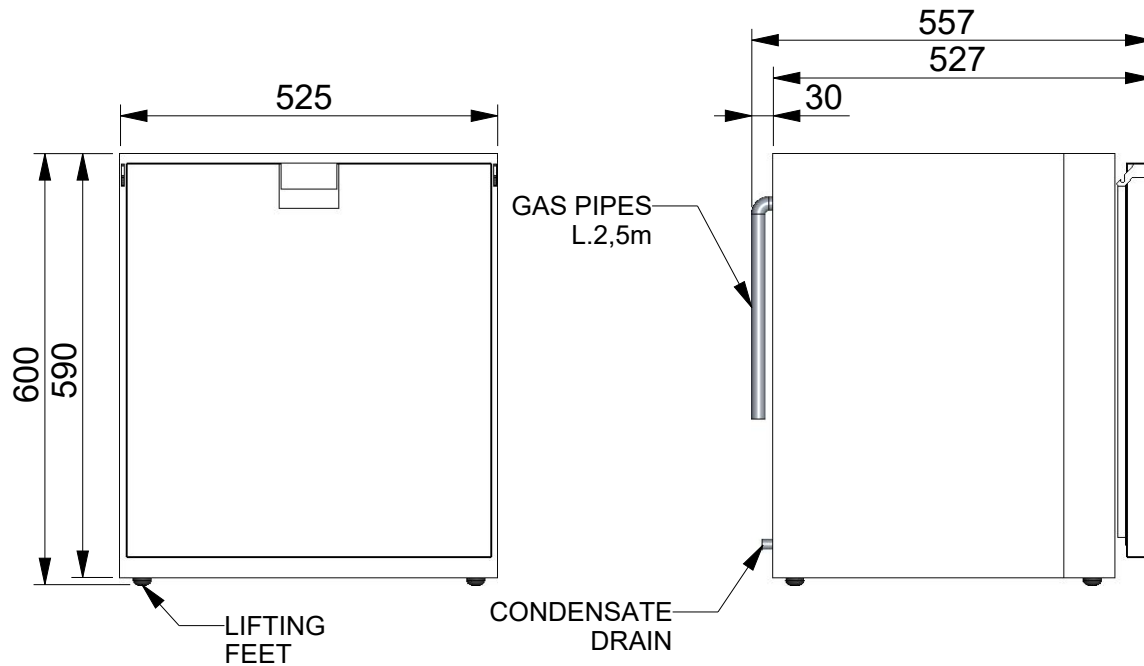

FEATURES CABINET CC1

- W525xD557xH590 [mm] Freezer capacity 75 Lt;
 - Range of temperature from -10°C to -20°C;
 - External plasticized galvanized metal sheet;
 - Internal walls in 304BA stainless steel (Polished);
 - Front part and door in 316SB stainless steel (Brushed);
 - Polyurethane foam insulation thickness 60mm;
 - Weight 33Kg (without compressor);
 - Condensate drainage connected by ¼ coupling;
 - N.01 Stainless steel drawer with direct extraction, and N01. internal drawer:
- Useful drawer dimensions:
 Upper drawer: W365 x D380 x H163
 Lower drawer: W365 x D400 x H276
- Gas expansion by capillary pipe;
 - Mechanical thermostat for temperature control;
 - External compressor (pipe lenght 2,5m);
 - In case of external use, do not expose the refrigerator directly to atmospheric agents, but protect it adequately with special covers.

CODICE PRODOTTO / PRODUCT CODE	REVISIONE / REVISION:
<h1>mod. CC1</h1>	R04
	DATA / DATE:
	01/01/2023



Via Confin 64, 30020 Torre di Mosto (Venezia) Italia Tel: +39 0421.325214 - Fax: +39 0421.325343
 E-Mail: info@frigonautica.it - P.IVA: 03687150270
www.frigonautica.it

PROPRIETA' DI FRIGONAUTICA srl
 Senza autorizzazione scritta della stessa il presente disegno non potrà essere utilizzato per la costruzione dell'oggetto rappresentato, nè venire comunicato a terzi o riprodotto anche parzialmente. La società proprietaria tutela i propri diritti a rigor di legge.
 ALL PROPRIETARY RIGHT RESERVED BY FRIGONAUTICA srl
 This drawing shall not be reproduced also partially or in any way utilized for the manufacture of the component or unit herein illustrated and must not be released to other parties without written consent. Any infringement will be legally pursued.

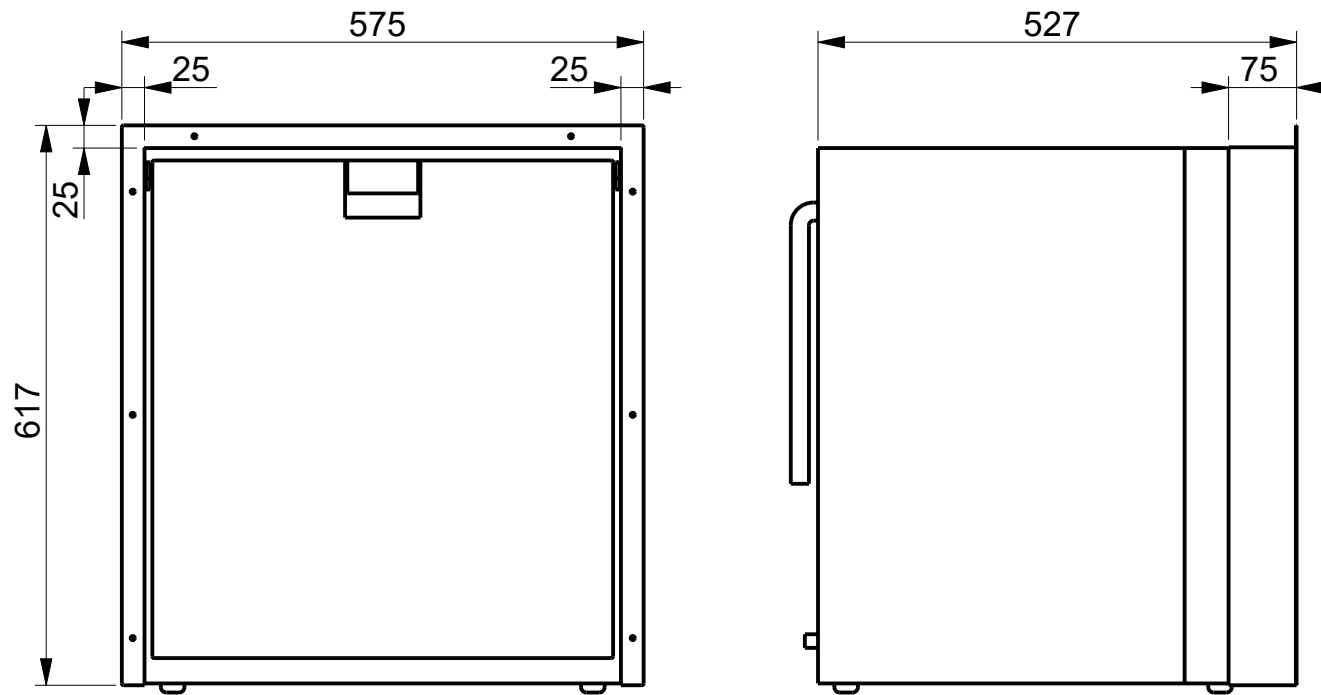

- FIXING KIT

Special stainless steel frame which allows to easily fix the cupboard to the furniture.

CODICE PRODOTTO / PRODUCT CODE	REVISIONE / REVISION:
<h1>mod. CC1</h1>	R04
	DATA / DATE:
	01/01/2023
 <p>Via Confin 64, 30020 Torre di Mosto (Venezia) Italia Tel: +39 0421.325214 - Fax: +39 0421.325343 E-Mail: info@frigonautica.it - P.IVA: 03687150270 www.frigonautica.it</p>	
<small> PROPRIETA' DI FRIGONAUTICA srl Senza autorizzazione scritta della stessa il presente disegno non potrà essere utilizzato per la costruzione dell'oggetto rappresentato, nè venire comunicato a terzi o riprodotto anche parzialmente. La società proprietaria tutela i propri diritti a rigor di legge. ALL PROPRIETARY RIGHT RESERVED BY FRIGONAUTICA srl This drawing shall not be reproduced also partially or in any way utilized for the manufacture of the component or unit herein illustrated and must not be released to other parties without written consent. Any infringement will be legally pursued. </small>	

ACCESSORIES - OPTIONAL

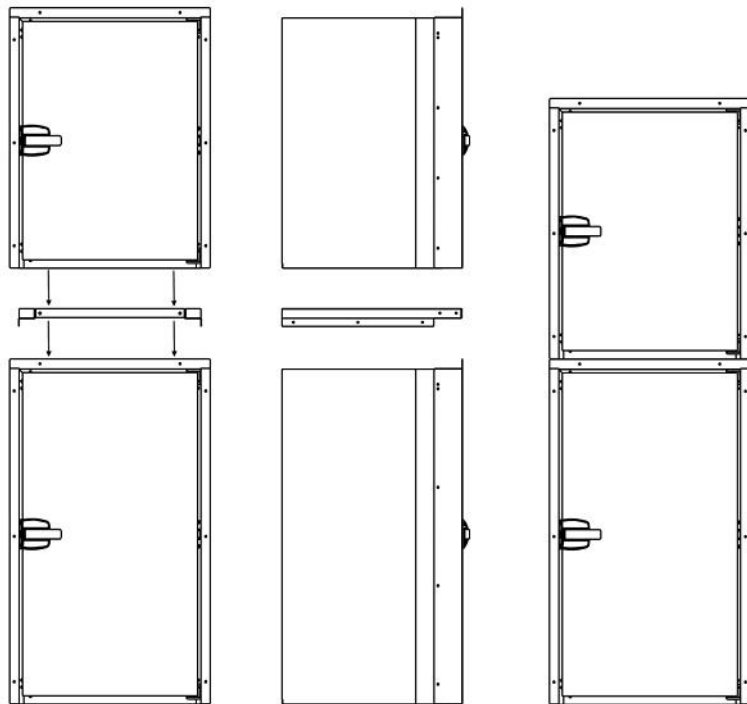

- OVERLAP KIT

Special overlapping kit in steel which allows you to fix and overlap two Frigonautica models with the same width.

The possible combinations are listed in the table below or on the website:

www.frigonautica.it/en/

	42	50	60	80	90	115	130	160	FC0	FC1	FC2	FC4	CC1
42													
50													
60													
80													
90													
115													
130													
160													
FC0													
FC1													
FC2													
FC4													
CC1							X		X	X	X	X	X

THE REBATE PROFILE
OF THE GASKET

HEATING-RESISTOR

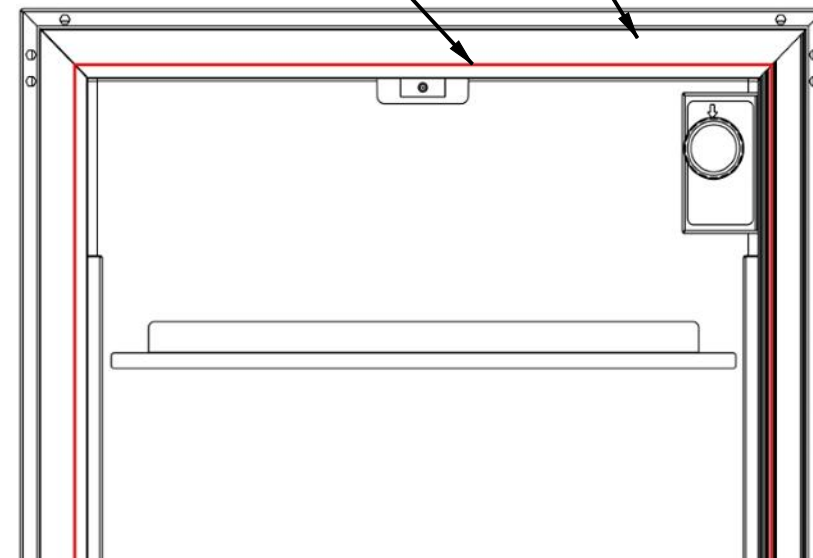

- ANTI-CONDENSATION RESISTANCE

Heating resistor mounted under the rebate profile of the gasket to prevent condensation. Recommended if the Freezer is installed in areas where the outside temperature exceeds 35 ° or in very humid places.

CODICE PRODOTTO / PRODUCT CODE	REVISIONE / REVISION:
<h1>mod. CC1</h1>	R04
	DATA / DATE:
	01/01/2023
 Frigonautica <i>Il freddo a misura di mare</i>	
Via Confin 64, 30020 Torre di Mosto (Venezia) Italia Tel: +39 0421.325214 - Fax: +39 0421.325343 E-Mail: info@frignonautica.it - P.IVA: 03687150270 www.frigonautica.it	
<small> PROPRIETA' DI FRIGONAUTICA srl Senza autorizzazione scritta della stessa il presente disegno non potrà essere utilizzato per la costruzione dell'oggetto rappresentato, nè venire comunicato a terzi o riprodotto anche parzialmente. La società proprietaria tutela i propri diritti a rigor di legge. ALL PROPRIETARY RIGHT RESERVED BY FRIGONAUTICA srl This drawing shall not be reproduced also partially or in any way utilized for the manufacture of the component or unit herein illustrated and must not be released to other parties without written consent. Any infringement will be legally pursued. </small>	

ACCESSORIES - OPTIONAL

- REMOTE ELECTRONICAL THERMOSTAT (DIGITAL THERMOSTAT)
In order to keep the internal temperature under control and have real time indications of fridge functionality.

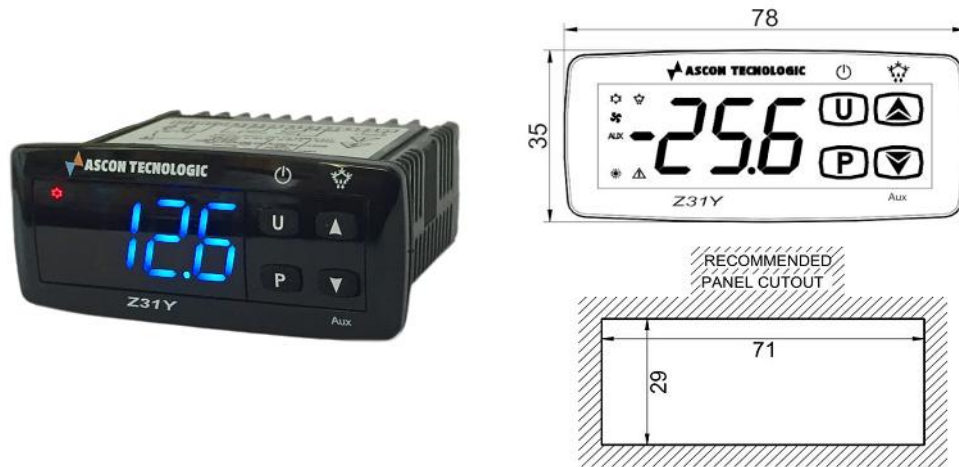

- QUICKLY COUPLINGS
Special couplings which allow to separate cabinet from compressor avoiding gas losing. That's very useful during installation which do not request skilled technical personnel.

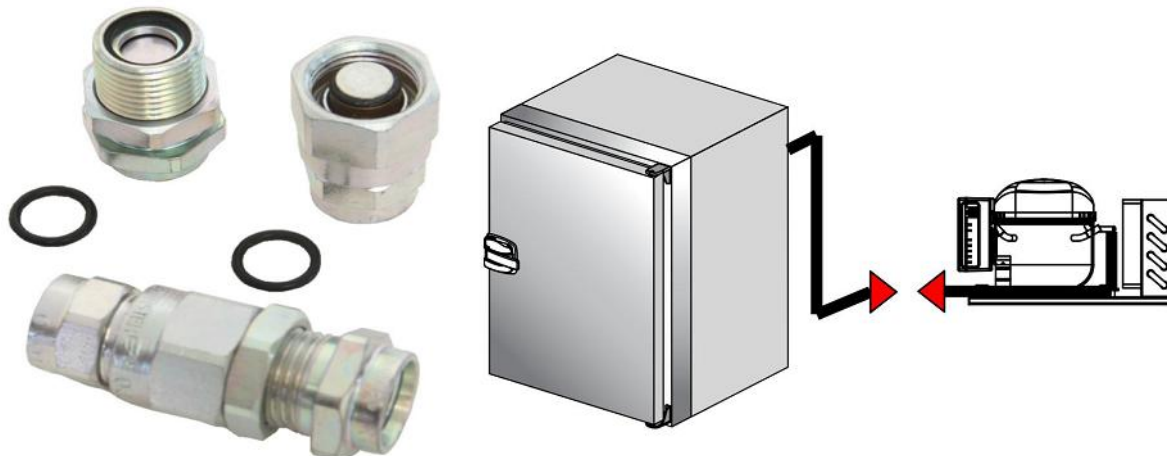

- SWITCHING POWER SUPPLY
Compact and powerful switching power supply.
Dimension: W120 x D270 x H50[mm] - 1,1Kg



Model	Input	Power input	Output	
RA15-110V 12Vdc	110Vac	168W	12Vdc	14A
RA15-110V 24Vdc	110Vac	168W	24Vdc	7A
RA15-220V 12Vdc	220Vac	168W	12Vdc	14A
RA15-220V 24Vdc	220Vac	168W	24Vdc	7A

CODICE PRODOTTO / PRODUCT CODE		REVISIONE / REVISION:	
<h1>mod. CC1</h1>		R04	
		DATA / DATE:	
		01/01/2023	
Frigonautica <i>Il freddo a misura di mare</i>			
Via Confin 64, 30020 Torre di Mosto (Venezia) Italia Tel: +39 0421.325214 - Fax: +39 0421.325343 E-Mail: info@frigonautica.it - P.IVA: 03687150270 www.frigonautica.it			
<small> PROPRIETA' DI FRIGONAUTICA srl Senza autorizzazione scritta della stessa il presente disegno non potrà essere utilizzato per la costruzione dell'oggetto rappresentato, nè venire comunicato a terzi o riprodotto anche parzialmente. La società proprietaria tutela i propri diritti a rigor di legge. ALL PROPRIETARY RIGHT RESERVED BY FRIGONAUTICA srl This drawing shall not be reproduced also partially or in any way utilized for the manufacture of the component or unit herein illustrated and must not be released to other parties without written consent. Any infringement will be legally pursued. </small>			

REFRIGERATION UNITS - 12/24Vdc

EV80

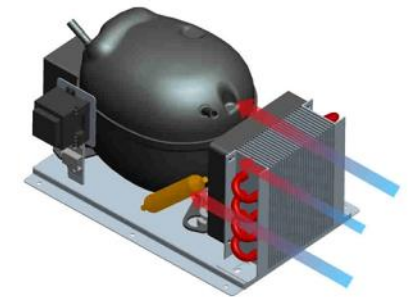
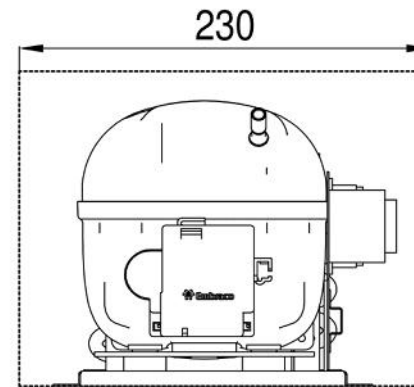
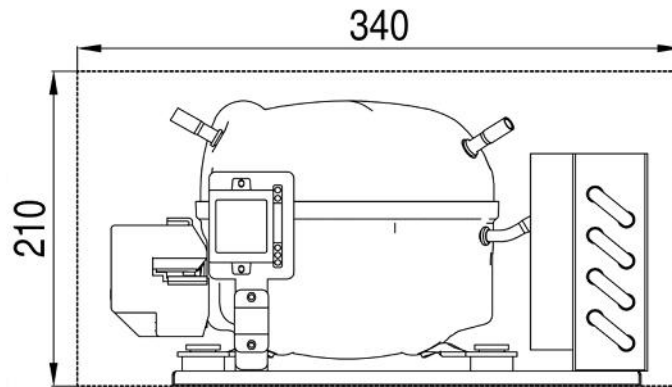

EAF80

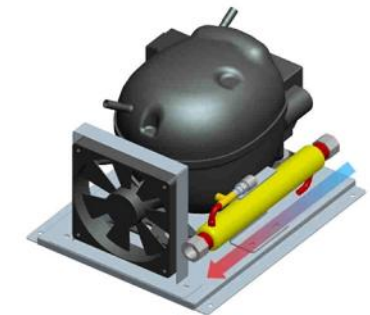
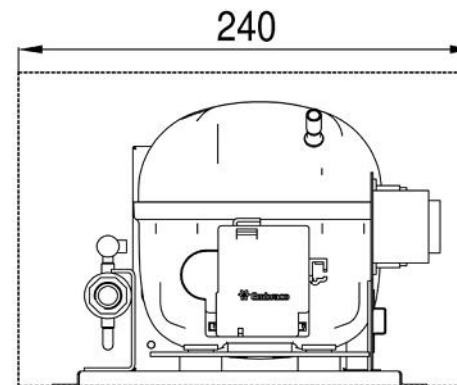
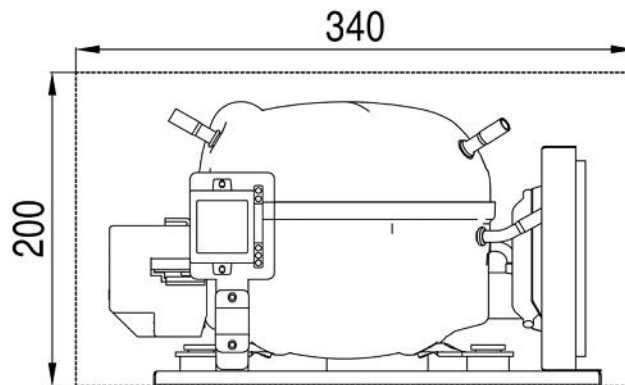

EV - FORCED AIR COOLED COMPRESSOR

The location of the refrigeration unit must be well ventilated and must allow adequate air passage. It is essential to provide good ventilation to the refrigerating unit. The correct working of the system is guaranteed if there is at least 100m³/h airflow to the compressor. We suggest air opening at least 400cm² for suction and at least 400cm² for warm air exit.

EAF - SEA WATER COOLED COMPRESSOR

The operation of the compressor is ensured by a specific counter-current sea water condenser. The water circulation pump or the external condenser outside the hull are options on request. The location of the refrigeration unit must be well ventilated and the water flow to the condenser must be constant.

CODICE PRODOTTO / PRODUCT CODE	REVISIONE / REVISION:
<h1>mod. CC1</h1>	R04
	DATA / DATE:
	01/01/2023
 <p>Frigonautica <i>Il freddo a misura di mare</i></p>	
<p>Via Confin 64, 30020 Torre di Mosto (Venezia) Italia Tel: +39 0421.325214 - Fax: +39 0421.325343 E-Mail: info@frignonautica.it - P.IVA: 03687150270 www.frigonautica.it</p>	
<small> PROPRIETA' DI FRIGONAUTICA srl Senza autorizzazione scritta della stessa il presente disegno non potrà essere utilizzato per la costruzione dell'oggetto rappresentato, nè venire comunicato a terzi o riprodotto anche parzialmente. La società proprietaria tutela i propri diritti a rigor di legge. ALL PROPRIETARY RIGHT RESERVED BY FRIGONAUTICA srl This drawing shall not be reproduced also partially or in any way utilized for the manufacture of the component or unit herein illustrated and must not be released to other parties without written consent. Any infringement will be legally pursued. </small>	

REFRIGERATION UNITS - 110-60Hz - 240Vac 50/60Hz

EV80

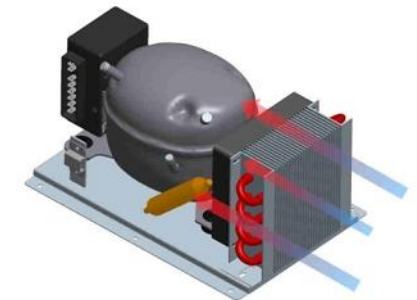
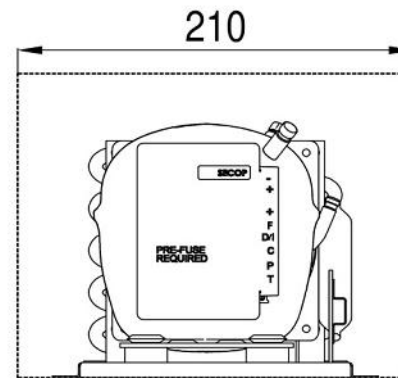
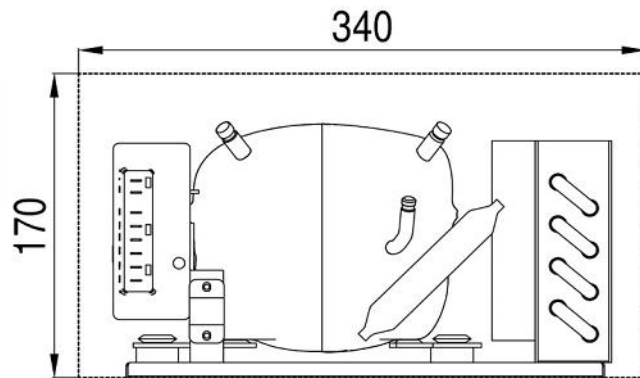

EAF80

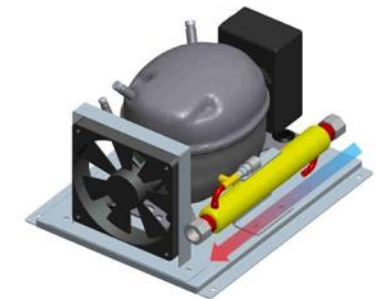
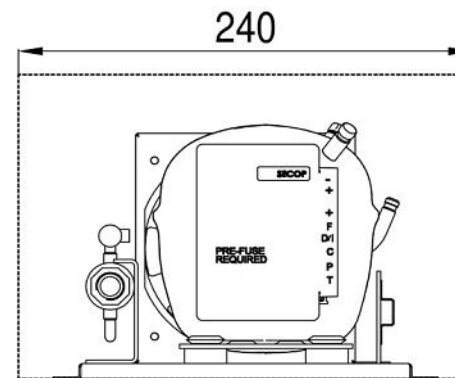
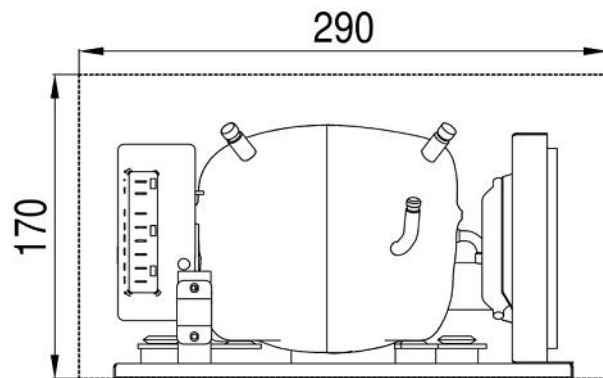

EV - FORCED AIR COOLED COMPRESSOR

The location of the refrigeration unit must be well ventilated and must allow adequate air passage. It is essential to provide good ventilation to the refrigerating unit. The correct working of the system is guaranteed if there is at least 100m³/h airflow to the compressor. We suggest air opening at least 400cm² for suction and at least 400cm² for warm air exit.

EAF - SEA WATER COOLED COMPRESSOR

The operation of the compressor is ensured by a specific counter-current sea water condenser. The water circulation pump or the external condenser outside the hull are options on request. The location of the refrigeration unit must be well ventilated and the water flow to the condenser must be constant.

CODICE PRODOTTO / PRODUCT CODE	REVISIONE / REVISION:
<h1>mod. CC1</h1>	R04
	DATA / DATE:
	01/01/2023
 <p>Frigonautica <i>Il freddo a misura di mare</i></p>	
<p>Via Confin 64, 30020 Torre di Mosto (Venezia) Italia Tel: +39 0421.325214 - Fax: +39 0421.325343 E-Mail: info@frigonautica.it - P.IVA: 03687150270 www.frigonautica.it</p>	
<small> PROPRIETA' DI FRIGONAUTICA srl Senza autorizzazione scritta della stessa il presente disegno non potrà essere utilizzato per la costruzione dell'oggetto rappresentato, nè venire comunicato a terzi o riprodotto anche parzialmente. La società proprietaria tutela i propri diritti a rigor di legge. ALL PROPRIETARY RIGHT RESERVED BY FRIGONAUTICA srl This drawing shall not be reproduced also partially or in any way utilized for the manufacture of the component or unit herein illustrated and must not be released to other parties without written consent. Any infringement will be legally pursued. </small>	