



**MODEL CS130C - Freezer capacity 84Lt**  
 Freezer (-10 ° C -20 ° C) with internal compressor.  
 The internal walls are in 304BA (polished) steel, while the external front and door are in 316SB (brushed) steel.  
 The refrigeration unit is available at 12 / 24Vdc, 110Vac 60Hz or at 220Vac 50Hz with forced air cooling.  
 Our refrigerators are made of high quality stainless steel and are also suitable for outdoor use, provided they are protected from the elements with appropriate covers.  
 Various options are also available.

STAR	TEMPERATURE	FROZEN FOOD STORAGE	FRESH FOOD STORAGE	MAXIMUM STORAGE
★	-6°	YES	NO	STORAGE 1 WEEK
★★	-12°	YES	NO	STORAGE 1 MONTH
★★★	-18°	YES	NO	STORAGE 1 YEAR
★ ★ ★ ★	-18°	YES	YES	STORAGE 1 YEAR

CODICE PRODOTTO / PRODUCT CODE	REVISIONE / REVISION:
<b>mod. CS130C</b>	R04
	DATA / DATE:
	01/01/2023



Via Confin 64, 30020 Torre di Mosto (Venezia) Italia Tel: +39 0421.325214 - Fax: +39 0421.325343  
 E-Mail: info@frigonautica.it - P.IVA: 03687150270  
[www.frigonautica.it](http://www.frigonautica.it)

PROPRIETA' DI FRIGONAUTICA srl  
 Senza autorizzazione scritta della stessa il presente disegno non potrà essere utilizzato per la costruzione dell'oggetto rappresentato, nè venire comunicato a terzi o riprodotto anche parzialmente. La società proprietaria tutela i propri diritti a rigor di legge.  
 ALL PROPRIETARY RIGHT RESERVED BY FRIGONAUTICA srl  
 This drawing shall not be reproduced also partially or in any way utilized for the manufacture of the component or unit herein illustrated and must not be released to other parties without written consent. Any infringement will be legally pursued.

# SPECIFICATIONS

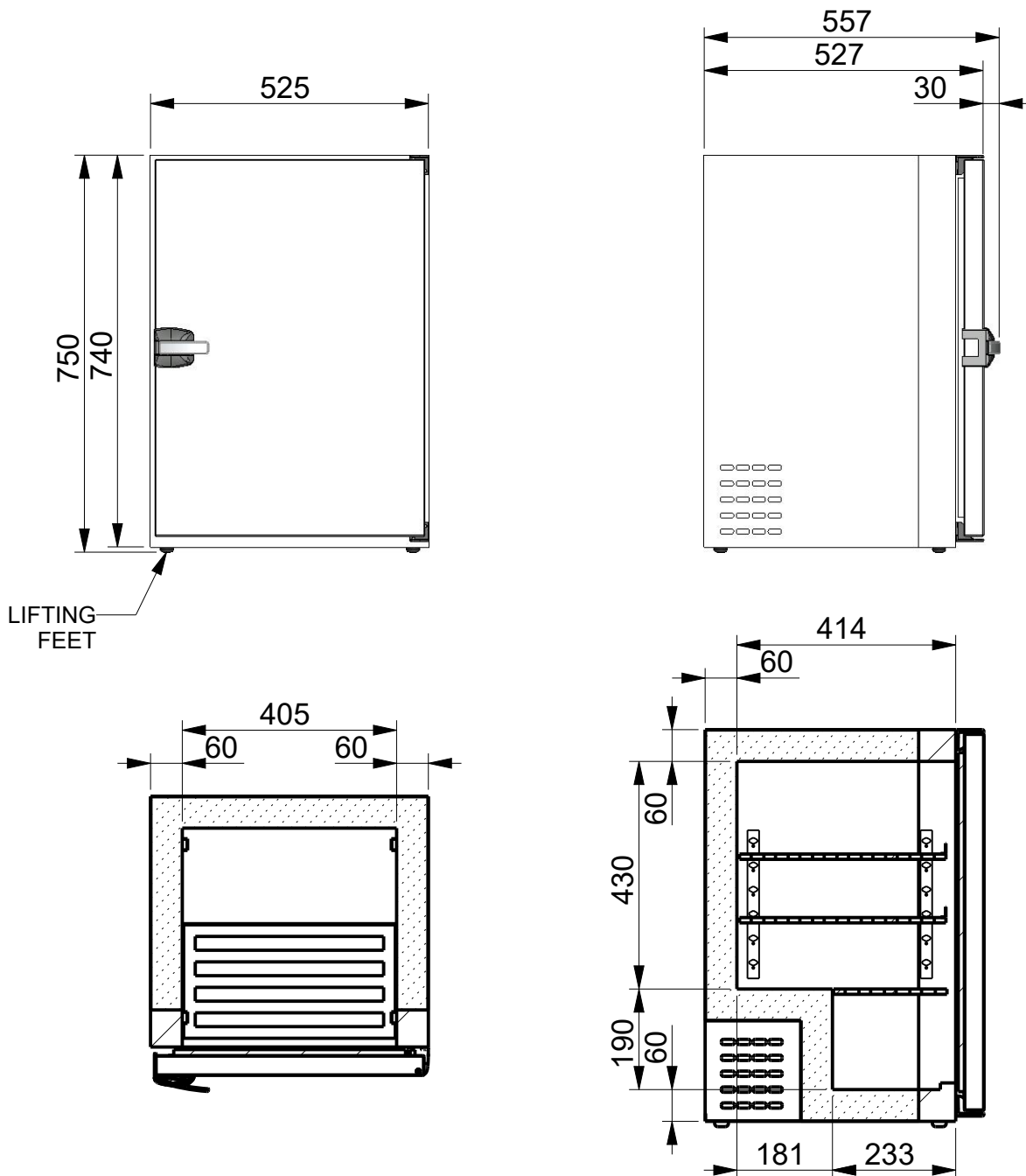

## FEATURES CABINET CS130C

- W525xD557xH740 [mm] Freezer capacity 84 Lt;
- Range of temperature from -10°C to -20°C;
- External plasticized galvanized metal sheet;
- Internal walls in 304BA stainless steel (Polished);
- Front part and door in 316SB stainless steel (Brushed);
- Predisposition for door opening on both the right and left;
- Polyurethane foam insulation thickness 60mm;
- Weight 38Kg (without compressor);
- Condensate drainage connected by ¼ coupling;

Optional: Internal condensate collection tray installed above the compressor;

- N. 01 fixed stainless steel shelf;
- N. 02 stainless steel shelves adjustable in height;
- Static evaporator in copper tube integrated into the insulation;
- Gas expansion by capillary pipe;
- Mechanical thermostat for temperature control;
- Internal compressor forced air cooled;
- In case of external use, do not expose the refrigerator directly to atmospheric agents, but protect it adequately with special covers.

CODICE PRODOTTO / PRODUCT CODE	REVISIONE / REVISION:
<h1>mod. CS130C</h1>	R04
	DATA / DATE:
	01/01/2023
 <p><i>Il freddo a misura di mare</i></p>	
<p>Via Confin 64, 30020 Torre di Mosto (Venezia) Italia Tel: +39 0421.325214 - Fax: +39 0421.325343  E-Mail: <a href="mailto:info@frigonautica.it">info@frigonautica.it</a> - P.IVA: 03687150270  <a href="http://www.frigonautica.it">www.frigonautica.it</a></p>	
<small>         PROPRIETA' DI FRIGONAUTICA srl          Senza autorizzazione scritta della stessa il presente disegno non potrà essere utilizzato per la costruzione dell'oggetto rappresentato, nè venire comunicato a terzi o riprodotto anche parzialmente. La società proprietaria tutela i propri diritti a rigor di legge.          ALL PROPRIETARY RIGHT RESERVED BY FRIGONAUTICA srl          This drawing shall not be reproduced also partially or in any way utilized for the manufacture of the component or unit herein illustrated and must not be released to other parties without written consent. Any infringement will be legally pursued.       </small>	

# ACCESSORIES - OPTIONAL

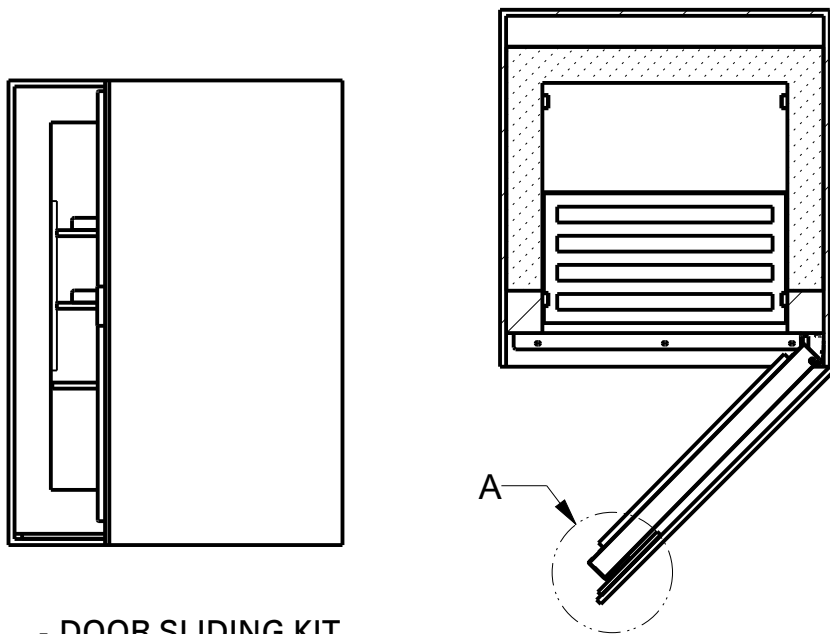

## - DOOR SLIDING KIT

Sliding mechanism which replaces the handle in the case of a fully built-in installation with an exterior cabinet door.

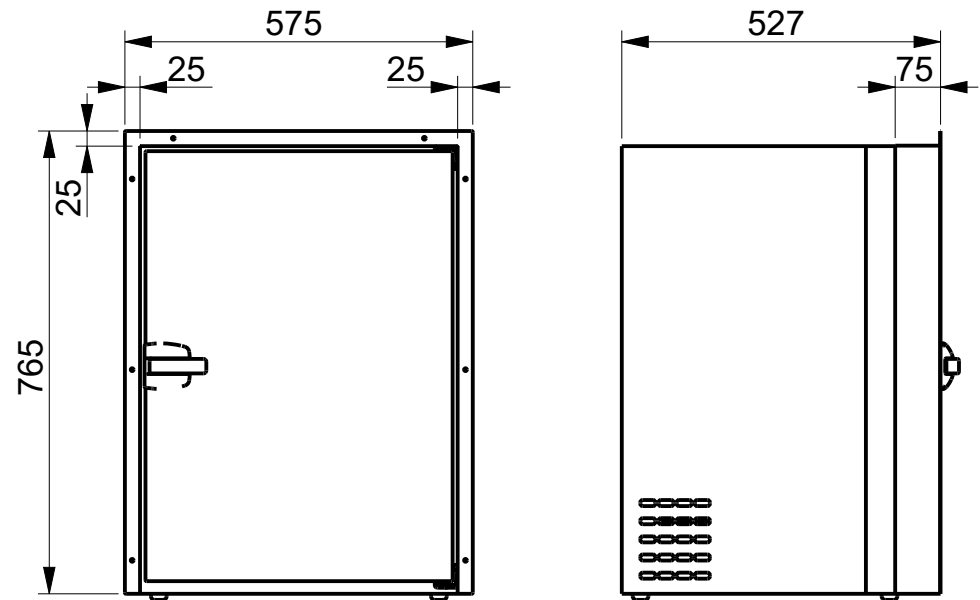

## - FIXING KIT

Special stainless steel frame which allows to easily fix the cupboard to the furniture.

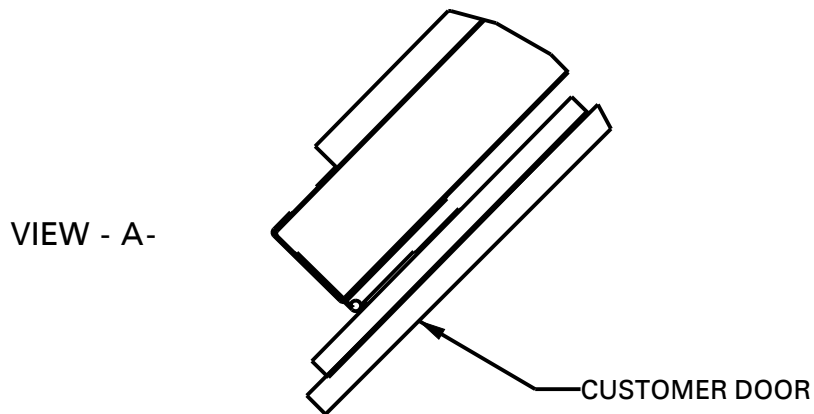

CODICE PRODOTTO / PRODUCT CODE	REVISIONE / REVISION:
<h1>mod. CS130C</h1>	R04
	DATA / DATE:
	01/01/2023
 <b>Frigonautica</b> <i>Il freddo a misura di mare</i>	
Via Confin 64, 30020 Torre di Mosto (Venezia) Italia Tel: +39 0421.325214 - Fax: +39 0421.325343 E-Mail: info@frigonautica.it - P.IVA: 03687150270 www.frigonautica.it	
<small>                     PROPRIETA' DI FRIGONAUTICA srl                      Senza autorizzazione scritta della stessa il presente disegno non potrà essere utilizzato per la costruzione dell'oggetto rappresentato, nè venire comunicato a terzi o riprodotto anche parzialmente. La società proprietaria tutela i propri diritti a rigor di legge.                      ALL PROPRIETARY RIGHT RESERVED BY FRIGONAUTICA srl                      This drawing shall not be reproduced also partially or in any way utilized for the manufacture of the component or unit herein illustrated and must not be released to other parties without written consent. Any infringement will be legally pursued.                 </small>	

## ACCESSORIES - OPTIONAL

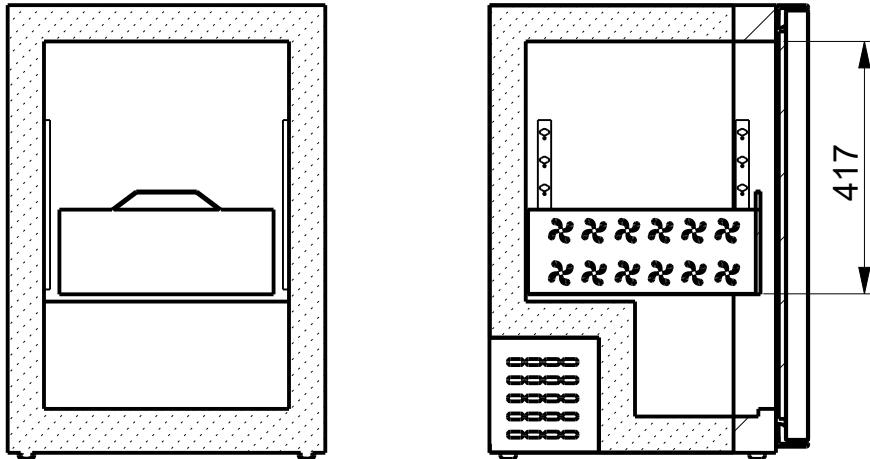

### - SLIDING DRAWERS

Special drawers complete with racks and locking device

No. Max drawers: 01

Net using space drawers (from bottom):

1 drawer W350 x D385 x H417 [mm]

### ATTENTION:

In order to pull out the drawers, is necessary that the door is opened at least 100°

CODICE PRODOTTO / PRODUCT CODE	REVISIONE / REVISION:
mod. CS130C	R04
	DATA / DATE:
	01/01/2023
 <b>Frigonautica</b> <i>Il freddo a misura di mare</i>	
Via Confin 64, 30020 Torre di Mosto (Venezia) Italia Tel: +39 0421.325214 - Fax: +39 0421.325343 E-Mail: info@frigonautica.it - P.IVA: 03687150270 www.frigonautica.it	
<small>PROPRIETA' DI FRIGONAUTICA srl Senza autorizzazione scritta della stessa il presente disegno non potrà essere utilizzato per la costruzione dell'oggetto rappresentato, nè venire comunicato a terzi o riprodotto anche parzialmente. La società proprietaria tutela i propri diritti a rigor di legge. ALL PROPRIETARY RIGHT RESERVED BY FRIGONAUTICA srl This drawing shall not be reproduced also partially or in any way utilized for the manufacture of the component or unit herein illustrated and must not be released to other parties without written consent. Any infringement will be legally pursued.</small>	

## ACCESSORIES - OPTIONAL

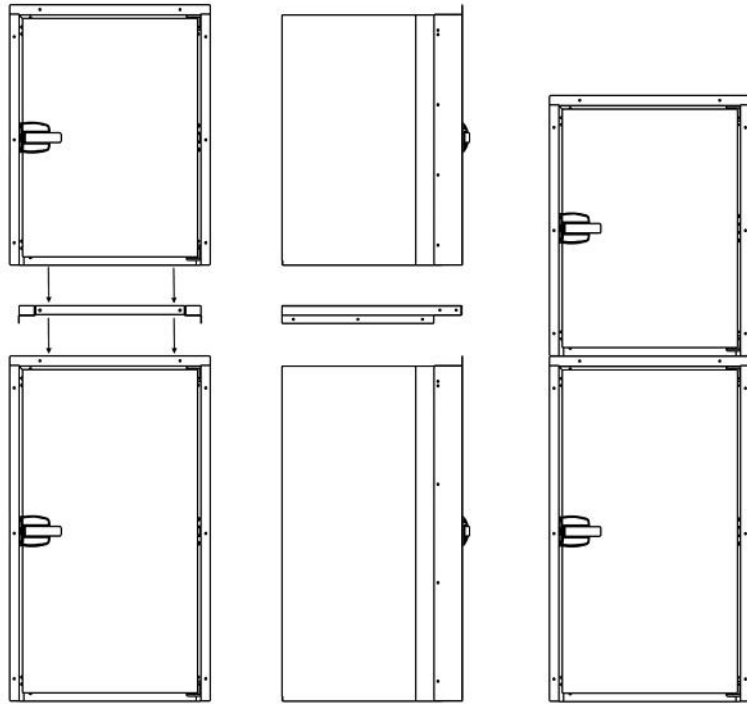

### - OVERLAP KIT

Special overlapping kit in steel which allows you to fix and overlap two Frigonautica models with the same width.

The possible combinations are listed in the table below or on the website:

[www.frigonautica.it/en/](http://www.frigonautica.it/en/)

	42	50	60	80	90	115	130	160	FC0	FC1	FC2	FC4	CC1
42													
50													
60													
80													
90													
115													
130					X		X		X	X	X	X	X
160													
FC0													
FC1													
FC2													
FC4													
CC1													

THE REBATE PROFILE  
OF THE GASKET

HEATING-RESISTOR

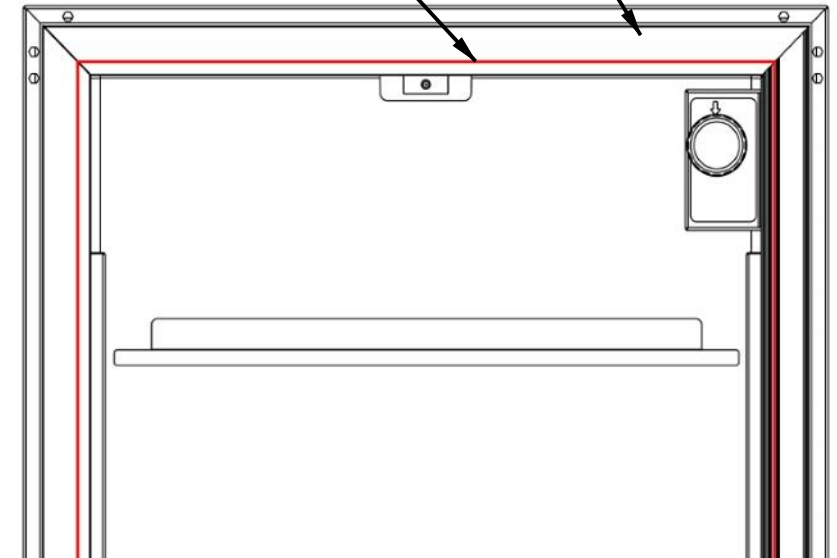

### - ANTI-CONDENSATION RESISTANCE

Heating resistor mounted under the rebate profile of the gasket to prevent condensation. Recommended if the Freezer is installed in areas where the outside temperature exceeds 35 ° or in very humid places.

CODICE PRODOTTO / PRODUCT CODE	REVISIONE / REVISION:
<h1>mod. CS130C</h1>	R04
	DATA / DATE:
	01/01/2023
 <b>Frigonautica</b> <i>Il freddo a misura di mare</i>	
Via Confin 64, 30020 Torre di Mosto (Venezia) Italia Tel: +39 0421.325214 - Fax: +39 0421.325343 E-Mail: <a href="mailto:info@frigonautica.it">info@frigonautica.it</a> - P.IVA: 03687150270 <a href="http://www.frigonautica.it">www.frigonautica.it</a>	
<small>                     PROPRIETA' DI FRIGONAUTICA srl                      Senza autorizzazione scritta della stessa il presente disegno non potrà essere utilizzato per la costruzione dell'oggetto rappresentato, nè venire comunicato a terzi o riprodotto anche parzialmente. La società proprietaria tutela i propri diritti a rigor di legge.                      ALL PROPRIETARY RIGHT RESERVED BY FRIGONAUTICA srl                      This drawing shall not be reproduced also partially or in any way utilized for the manufacture of the component or unit herein illustrated and must not be released to other parties without written consent. Any infringement will be legally pursued.                 </small>	

## ACCESSORIES - OPTIONAL

- REMOTE ELECTRONICAL THERMOSTAT (DIGITAL THERMOSTAT)  
In order to keep the internal temperature under control and have real time indications of fridge functionality.

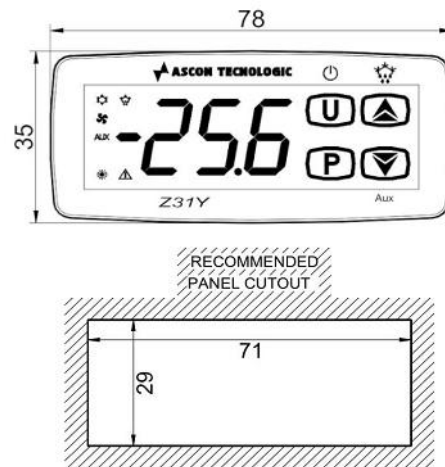

- SWITCHING POWER SUPPLY  
Compact and powerful switching power supply.  
Dimension: W120 x D270 x H50[mm] - 1,1Kg



Model	Input	Power input	Output	
RA15-110V 12Vdc	110Vac	168W	12Vdc	14A
RA15-110V 24Vdc	110Vac	168W	24Vdc	7A
RA15-220V 12Vdc	220Vac	168W	12Vdc	14A
RA15-220V 24Vdc	220Vac	168W	24Vdc	7A

CODICE PRODOTTO / PRODUCT CODE	REVISIONE / REVISION:
<h1>mod. CS130C</h1>	R04
	DATA / DATE:
	01/01/2023
 <b>Frigonautica</b> <i>Il freddo a misura di mare</i>	
Via Confin 64, 30020 Torre di Mosto (Venezia) Italia Tel: +39 0421.325214 - Fax: +39 0421.325343 E-Mail: info@frigonautica.it - P.IVA: 03687150270 www.frigonautica.it	
<small>                 PROPRIETA' DI FRIGONAUTICA srl                  Senza autorizzazione scritta della stessa il presente disegno non potrà essere utilizzato per la costruzione dell'oggetto rappresentato, nè venire comunicato a terzi o riprodotto anche parzialmente. La società proprietaria tutela i propri diritti a rigor di legge.                  ALL PROPRIETY RIGHT RESERVED BY FRIGONAUTICA srl                  This drawing shall not be reproduced also patially or in any way utilized for the manufacture of the component or unit herein illustrated and must not be released to other parties without written consent. Any infringement will be legally pursued.             </small>	

# REFRIGERATION UNITS - 12/24Vdc - 110Vac-60Hz - 240Vac 50/60Hz

- COOLED BY FORCED AIR

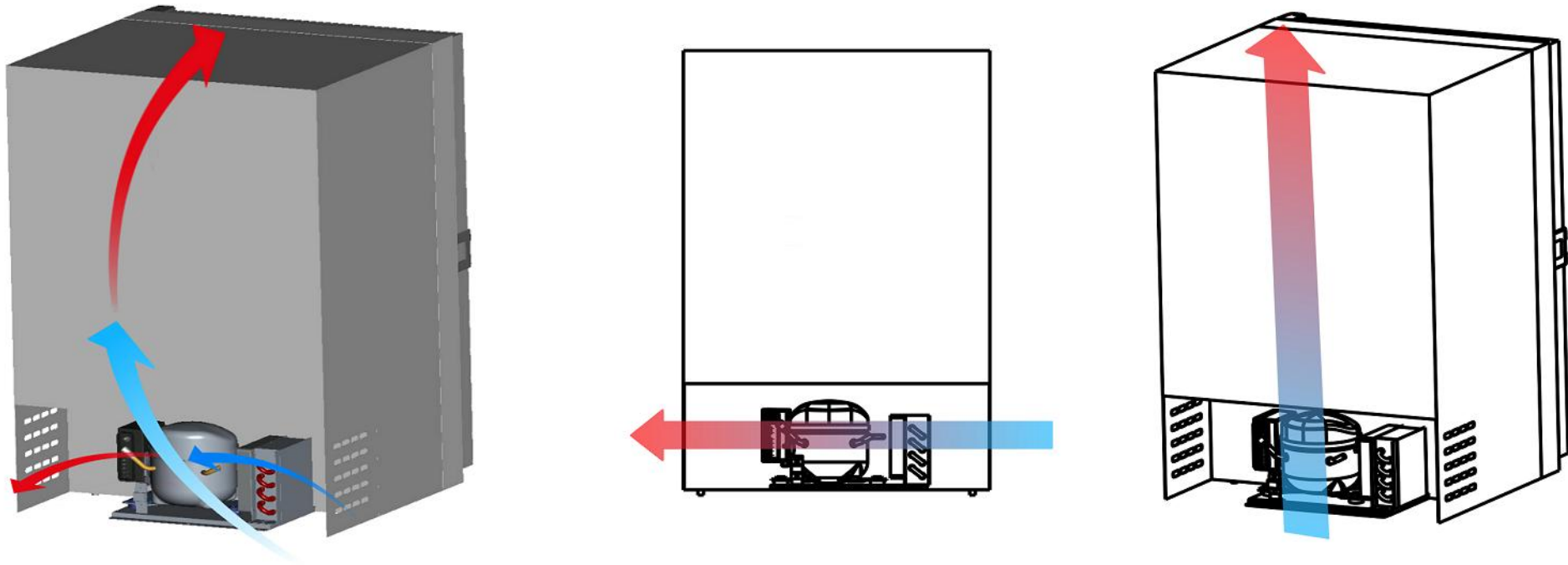

## EV - FORCED AIR COOLED COMPRESSOR

The series of refrigerators or freezers with compressor integrated in the cabinet only use the forced air cooled compressor.

The location of the cabinet must allow for adequate air passage. It is essential to provide good ventilation for the refrigeration unit. Correct operation of the system is guaranteed if there is at least 100 m<sup>3</sup>/h of air flow to the compressor. We recommend an air opening of at least 400 cm<sup>2</sup> for the intake and at least 400 cm<sup>2</sup> for the hot air outlet.

CODICE PRODOTTO / PRODUCT CODE	REVISIONE / REVISION:
mod. CS130C	R04
	DATA / DATE:
	01/01/2023
 <i>Il freddo a misura di mare</i>	
Via Confin 64, 30020 Torre di Mosto (Venezia) Italia Tel: +39 0421.325214 - Fax: +39 0421.325343 E-Mail: info@frignonautica.it - P.IVA: 03687150270 www.frigonautica.it	
<small>PROPRIETA' DI FRIGNAUTICA srl Senza autorizzazione scritta della stessa il presente disegno non potrà essere utilizzato per la costruzione dell'oggetto rappresentato, nè venire comunicato a terzi o riprodotto anche parzialmente. La società proprietaria tutela i propri diritti a rigor di legge. ALL PROPRIETARY RIGHT RESERVED BY FRIGNAUTICA srl This drawing shall not be reproduced also partially or in any way utilized for the manufacture of the component or unit herein illustrated and must not be released to other parties without written consent. Any infringement will be legally pursued.</small>	